

R180

AVR

Installation and maintenance

R180 AVR

This manual concerns the alternator AVR which you have just purchased. We wish to draw your attention to the contents of this maintenance manual.

SAFETY MEASURES

Before using your machine for the first time, it is important to read the whole of this installation and maintenance manual.

All necessary operations and interventions on this machine must be performed by a qualified technician.

Our technical support service will be pleased to provide any additional information you may require.

The various operations described in this manual are accompanied by recommendations or symbols to alert the user to potential risks of accidents. It is vital that you understand and take notice of the following warning symbols.

WARNING

Warning symbol for an operation capable of damaging or destroying the machine or surrounding equipment.



Warning symbol for general danger to personnel.



Warning symbol for electrical danger to personnel.



All servicing or repair operations performed on the AVR should be undertaken by personnel trained in the commissioning, servicing and maintenance of electrical and mechanical components.



When the generator is driven at a frequency below 28 Hz for more than 30 seconds with an analogue AVR, its AC power supply must be disconnected.

WARNING

This AVR can be incorporated in a EC-marked machine. This manual is to be given to the end user.

© - We reserve the right to modify the characteristics of this product at any time in order to incorporate the latest technological developments. The information contained in this document may therefore be changed without notice.

This document may not be reproduced in any form without prior authorisation. All brands and models have been registered and patents applied for.

R180 AVR

CONTENTS

1 - GENERAL DESCRIPTION	4
2 - AVR PARAMETERS	5
3 - TECHNICAL SPECIFICATION	6
4 - MAIN FUNCTION OF THE AVR	7
4.1 - Connection diagram for 180V to 310V voltage range	7
4.2 - Connection diagram for 300V to 530V voltage range with droop powered by AREP+	8
4.3 - Connection diagram for 300V to 530V voltage range with droop powered by PMG	9
5 - AVR SETTINGS	10
6 - TROUBLESHOOTING CHART	11
7 - MULTIMETER TEST	12
8 - STATIC TEST PROCEDURE	13
8.1 - Test equipment	13
8.2 - Connection	13
8.3 - Test procedure	14
9 - DIMENSIONS	15
10 - SPARE PARTS	16
10.1 - Designation	16
10.2 - Technical support service	16

Disposal and recycling instructions

R180

AVR

1 - GENERAL DESCRIPTION

The R180 is a fully solid-state automatic voltage regulator (AVR) which is used for excitation of a brushless alternator powered by a Permanent-Magnet (PMG) exciter or by auxiliary windings.

The alternator voltage between phases V-W is sampled, processed and converted to a direct current value. This signal is compared to the reference value which is internally generated depending upon the voltage setting. The comparison is made by a PID controller, which controls the alternator excitation. The power circuit uses a pulse width modulated (PWM) IGBT circuit to adjust the field current, which gives a good dynamic/transient response.

It takes a 1 and 5A signal from a droop current transformer in U phase to give a voltage droop which allows the alternator to operate in parallel.

The R180 has an accessory input, which can be used as a remote potentiometer terminal when connected to a 1 K Ω potentiometer or takes $\pm 4.5V$ DC in order to change the terminal voltage.

It has an under frequency voltage roll-off function to prevent alternator overfluxing in the event of underspeed operation. The AVR has a potentiometer for setting the knee-point for under frequency roll-off and a 50Hz/60Hz selection jumper. This jumper makes it easy to select the AVR frequency for a 50Hz/60Hz alternator.

The AVR output is limited to 6A. This limiter is delayed type so that it does not interfere with field forcing. In the event of loss of the sensing input, the AVR provides 9A DC excitation current for 5 seconds and reduces the excitation current.

The R180 is triggered from the alternator remanent voltage.

R180

AVR

2 - AVR PARAMETERS

UFRO selection link

Open - 60Hz operating mode.

Closed - 50Hz operating mode.

UFRO potentiometer

45Hz to 55Hz in 50 Hz mode.

55Hz to 65Hz in 60 Hz mode.

Voltage

The working voltage is set by the potentiometer marked "V".

Drop

The quadrature droop is set by the potentiometer marked "Drop".

Auxiliary input and external potentiometer range

The auxiliary input range is set by the potentiometer marked "Acc".

This potentiometer sets the maximum voltage range for the external potentiometer or the auxiliary input range.

Stability

This potentiometer is used to set the alternator output voltage stability. Turning it clockwise increases the speed. The setting is reached when the stability potentiometer position (set CW) allow to be at the starting of a voltage instability, then set the potentiometer 1 turn below (set CCW).

Indications

- Over Excitation limit
- Loss of sensing voltage
- UFRO

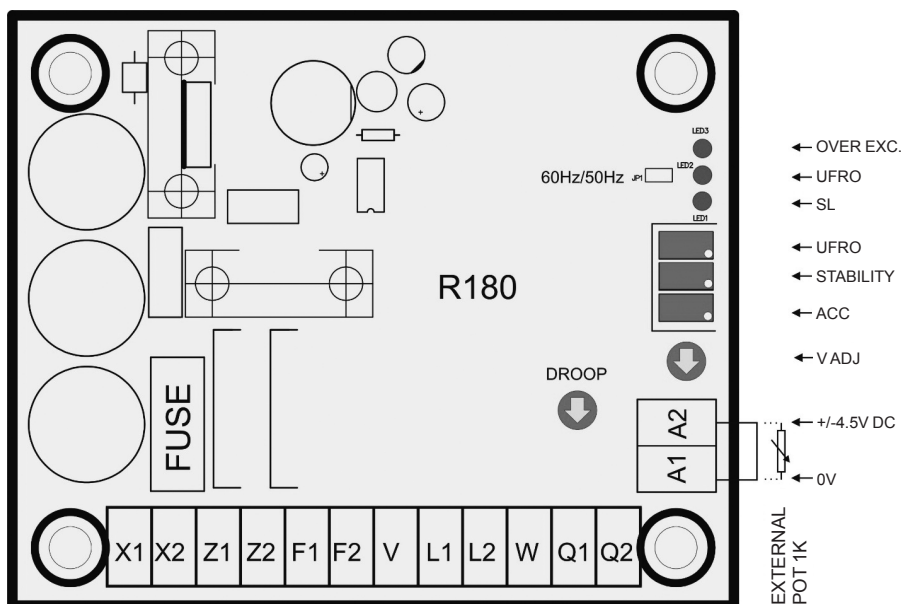

R180 AVR

3 - TECHNICAL SPECIFICATION

1	Sensing input	3-ph/2-ph - 220/230/240/380/400/415 volts for 50 Hz 3-ph/2-ph - 208/240/277/380/416/440/480 volts for 60 Hz
2	Voltage range high	300V to 530V
3	Voltage range low	180V to 310V
4	Droop	1 and 5A AC in U phase
5	Droop range	8% droop at 0.8 PF
6	PMG input power	Continuous: 240V RMS +10% Momentary 5 s: 240V RMS + 30 Up to 240 Hz
7	AREP+ input power	Continuous: 250V peak+10% Momentary 10 s: 350V peak +5% - Up to 75 Hz
8	Excitation current	6A DC continuous 9A for 5 seconds (short-circuit operation)
9	Regulation	± 0.5% at AVR sensing terminals
10	Maximum excitation limit	6A DC (factory setting)
11	Maximum excitation limit delay	30 sec. (factory setting)
12	Under frequency protection	48.5 Hz/58.5 Hz for 50 Hz/60 Hz operation
13	Slope	1.2X (120%) V/Hz
14	Remote potentiometer	1 kOhm for ± 10% adjustment
15	Accessory Input	± 4.5V DC for ±15%
16	Loss of sensing	Shuts down after 5 sec. when sensing open
17	Weight	500 g approximate
18	Dimensions	140 mm x 115 mm x 70 mm
19	Temperature range	-25°C to +70°C
20	Storage temperature range	-40°C to +80°C
21	Thermal drift	0.5% for 20°C change
22	Fuse	FST 10A 250V

R180

AVR

4 - MAIN FUNCTION OF THE AVR

4.1 - Connection diagram for 180V to 310V voltage range

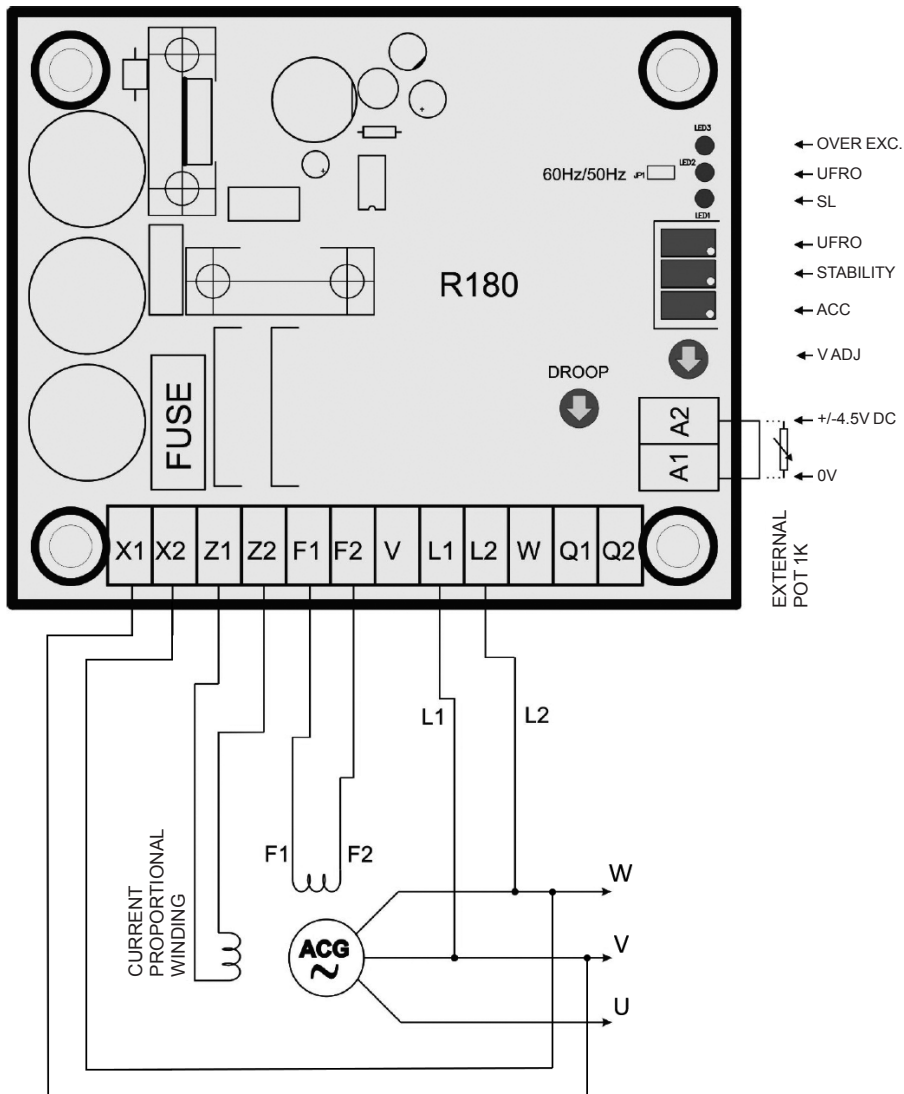

R180 AVR

4.2 - Connection diagram for 300V to 530V voltage range with droop powered by AREP+

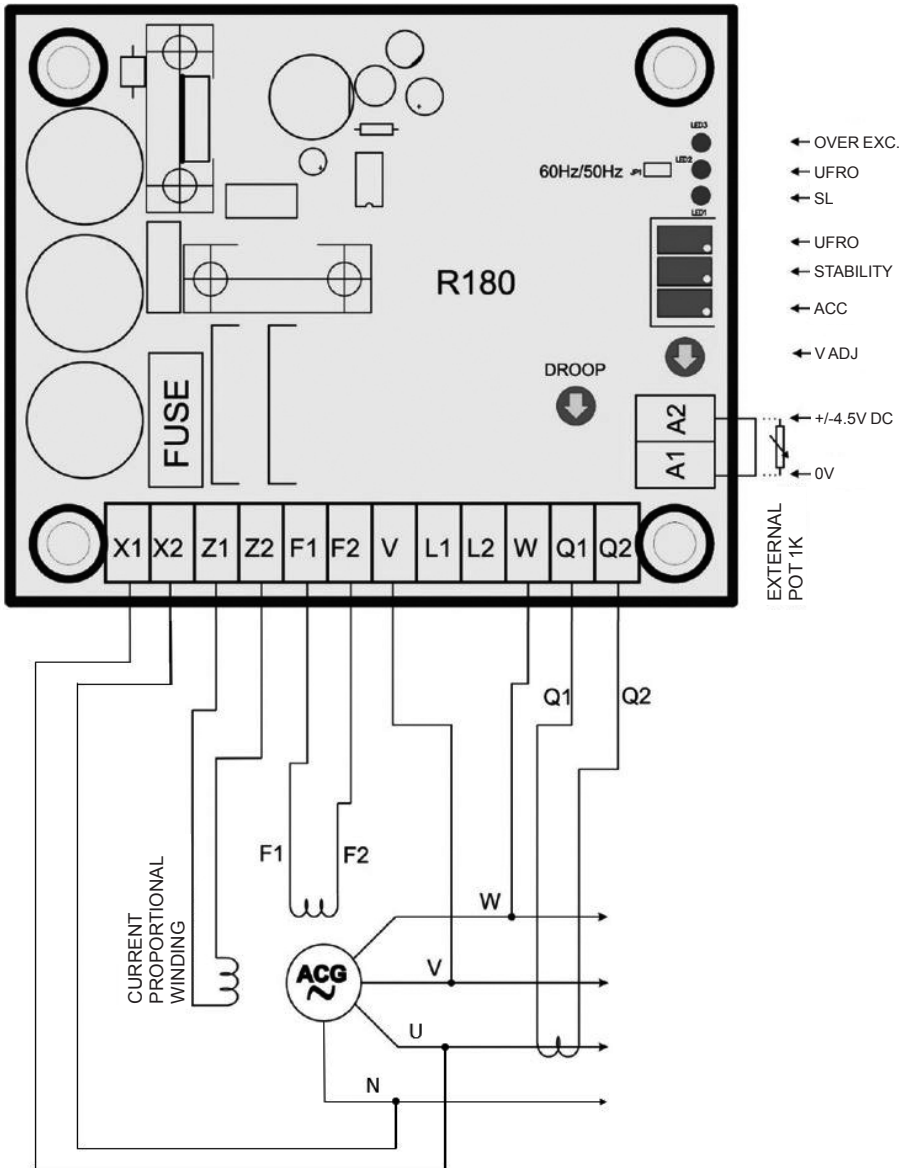

R180

AVR

4.3 - Connection diagram for 300V to 530V voltage range with droop powered by PMG

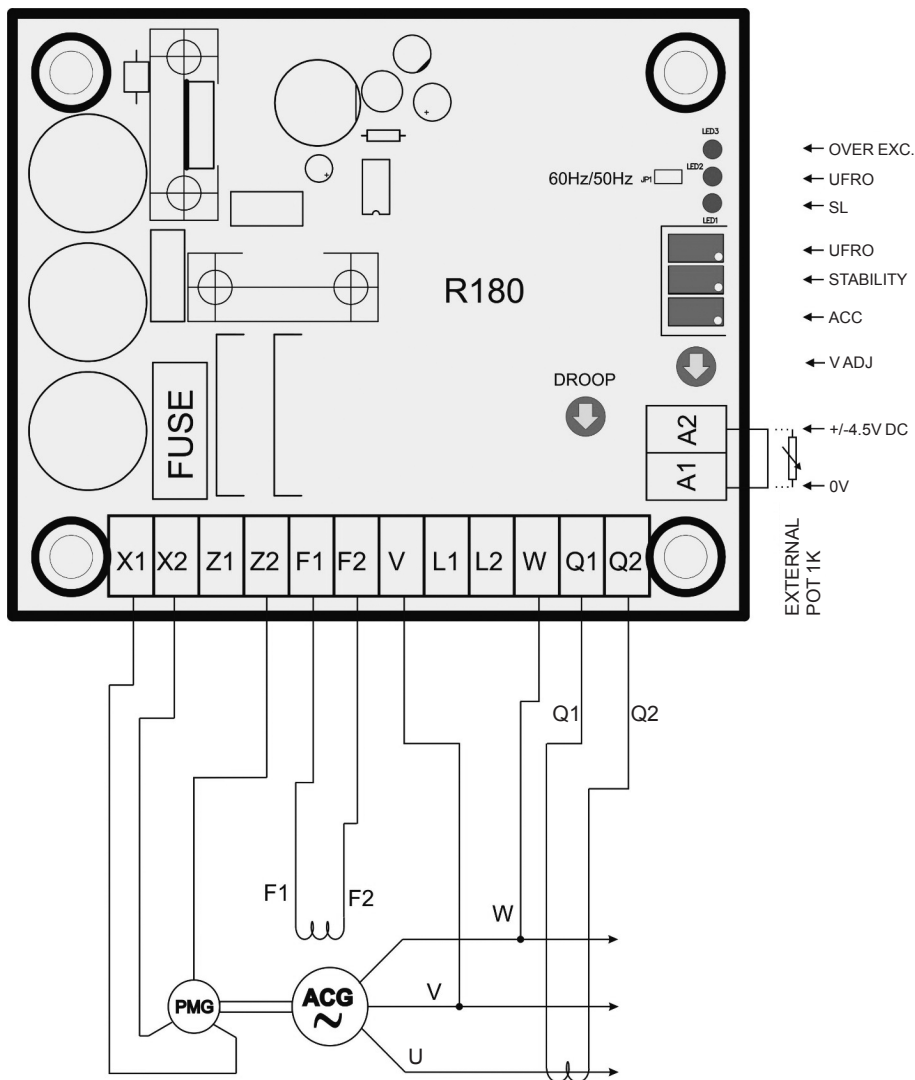

R180 AVR

5 - AVR SETTINGS



WARNING! TO PREVENT ELECTRIC SHOCK AND PERSONAL INJURY, CARE MUST BE TAKEN NOT TO TOUCH LIVE PARTS.



CAUTION! ADJUSTMENTS MUST BE DONE CAREFULLY AND GRADUALLY WHILE THE ALTERNATOR IS RUNNING OTHERWISE THE SYSTEM MAY EXPERIENCE FLUCTUATIONS.

- VOLT : Full CCW
- STAB : Centre of travel
- UFRO : Select 50Hz or 60Hz mode

Start-up

- Check all settings are as per the paragraph "Initial Settings".
- Start the prime mover and bring the alternator up to rated speed (rpm).
- The voltage at the terminals will show voltage build-up.
- Adjust the voltage at the terminals using the voltage adjustment potentiometer.
- If oscillations are seen on the voltmeter (A.C.) indicating the alternator terminal voltage, gradually turn the "STABILITY" trimmer on the R180 clockwise and stop turning it at the position where the oscillations disappear.

- If oscillations are not seen on voltage build-up, turn the "STABILITY" trimmer anticlockwise till oscillations appear and then slightly turn it clockwise to remove any oscillation. This will help tune the controller and alternator time constants.

- Set the Ufro knee point at 47.5Hz for 50Hz or 57Hz for 60Hz.

- If an external voltage adjustment potentiometer is required, stop the alternator and connect a 1 kOhm potentiometer in place of the link at terminals A1 and A2.

- If droop is required, connect the droop current transformer at terminals Q1 and Q2.

R180 AVR

6 - TROUBLESHOOTING CHART

Symptom	Cause	Action
No voltage build-up	Fuse links blown	Change the fuse links
	Low residual voltage across X1 and X2 terminals	Run alternator at correct rpm. If the problem persists, disconnect the AVR and connect a 24VDC battery between F1 and F2. This action will increase the residual voltage. Reconnect AVR.
	Incorrect wiring	Check the wiring complies with the wiring diagram and repair if necessary
	Voltmeter defective	Replace the voltmeter
	Faulty AVR	Replace the AVR
Voltage too high	Incorrect voltage setting	Set the voltage to the required value
	Faulty AVR	Replace the AVR
Low voltage	External potentiometer link open	Connect link or potentiometer as necessary
	Loss of sensing voltage	Connect as per the diagram
	Prime mover rpm falls	Set rpm
Incorrect regulation	Prime mover rpm falls	Set rpm
	Highly distorted non-linear load	Reduce non-linear load
	Alternator running on very low P.F.	P.F. correction required
	Unbalanced load	Redistribute the load equally over all three phases
	Faulty AVR	Replace the AVR
	Rotating diodes failed	Replace the diodes
	Drop connected	Remove droop connection if not needed
Voltage unstable	Incorrect wiring	Check and repair the wiring. Make sure that the contacts are screwed in tightly.
	Stability setting incorrect	Adjust the stability potentiometer
Voltage builds-up but collapses/erratic behaviour	Incorrect wiring	Check and repair the wiring. Make sure that the contacts are screwed in tightly.
	Incorrect circuit board settings	Set as per instructions in the manual

R180

AVR

7 - MULTIMETER TEST

WARNING

The freewheel diode can be tested by a digital multimeter in diode tester mode.

Connect the red lead to F2 and the black lead on the multimeter to F1. The multimeter will display 0.4V to 0.6V in diode test mode if the freewheel diode is OK. 0V or OL on the multimeter indicates a faulty freewheel diode.

IGBT Tab is connected to +DC bus and A1 is connected to -DC bus on the AVR.

These two connections can be used to test the IGBT and input bridge connected at X1, X2, Z1 and Z2.

Connect the multimeter black lead to IGBT Tab.

Connect the red lead to X1: the multimeter will display 0.4V to 0.6V.

Connect the red lead to X2: the multimeter will display 0.4V to 0.6V.

Connect the red lead to Z1: the multimeter will display 0.4V to 0.6V.

Connect the red lead to Z2: the multimeter will display 0.4V to 0.6V.

Connect the red lead to A1 and connect the black lead to X1: the multimeter will display 0.4V to 0.6V.

Connect the black lead to X2: the multimeter will display 0.4V to 0.6V.

Connect the black lead to Z1: the multimeter will display 0.4V to 0.6V.

Connect the black lead to Z2: the multimeter will display 0.4V to 0.6V.

If the multimeter displays 0V or OL in diode test, the bridge rectifier diodes are faulty.

If the fuses are open, X1 and Z2 will display OL in diode test mode.

If IGBT Tab and F1 display 0 ohm, the IGBT is faulty.

Sensing input resistance test

Resistance between V and A1:
1.3 M Ω approx.

Resistance between L1 and A1:
1 M Ω approx.

Resistance between L2 and A1:
1 M Ω approx.

Resistance between W and A1:
1.3 M Ω approx.

R180 AVR

8 - STATIC TEST PROCEDURE

8.1 - Test equipment

- 3-phase variac
- AC/DC voltmeter
- 100 Watt bulb
- 1 K potentiometer
- 250V/110V transformer

8.2 - Connection

- Connect the 100 W bulb between the F1 and F2 terminals on the AVR
- Connect the 110V transformer output to X1 and X2 on the AVR
- Connect the 250V end of the transformer to U and N on the variac
- V output on the variac to V terminal on the AVR
- W on the variac to W terminal on the AVR
- Connect the 1 K Ω potentiometer to A1 and A2

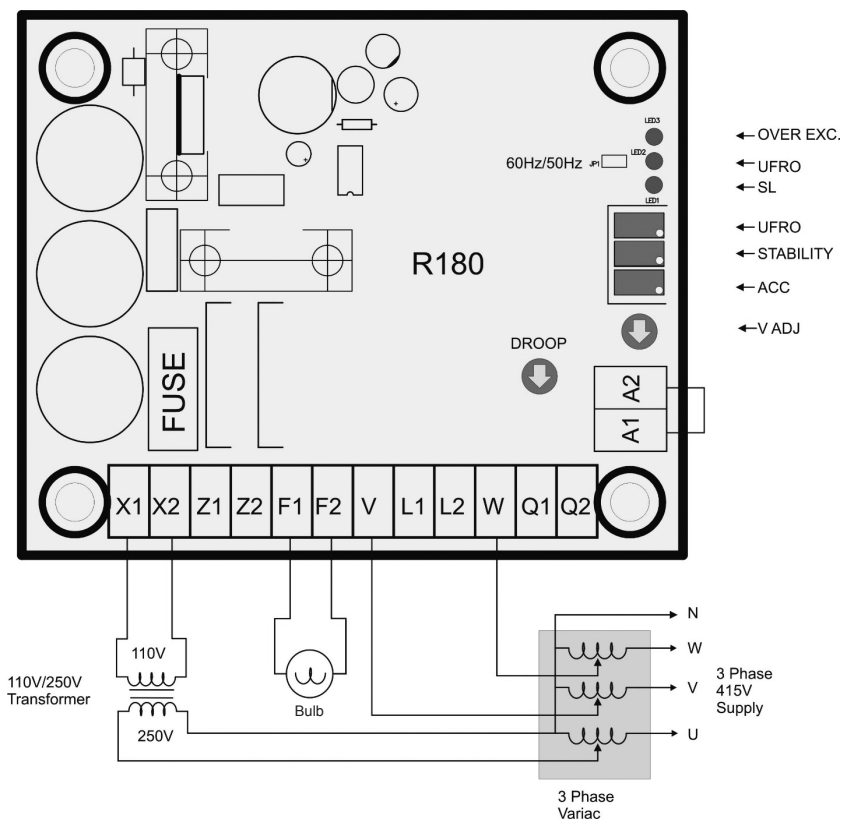

R180 AVR

8.3 - Test procedure

Build-up test

To test build-up, start the variac at 0 volts and set the output voltage to around 5VAC between X1 and X2. If the AVR is OK, the DC voltmeter will display a stable value between terminals F1 and F2 on the AVR which will increase as the input power increases.

Voltage control test

The default AVR voltage setpoint is around 415VAC. The bulb should remain ON for a supply voltage level below the setpoint i.e. around 415VAC and should turn OFF when the input voltage is increased above the setpoint by the variac. The bulb transition will be gradual because the AVR is stable.

External potentiometer test

Connect the 1 K potentiometer between terminals A1 and A2. The external potentiometer will allow the setpoint to drop to 330V from 415V (minimum and maximum positions). This can be verified by the voltage control test described above.

UFRO test

Set the variac output voltage to 400VAC. The bulb will up light because the setpoint is 415V. Now turn on the switch which is connected to the 50Hz/60Hz input. The bulb will gradually go OFF due to the change in the UFRO setpoint. If the switch is turned OFF the bulb will light up again. In 60Hz mode the UFRO LED will light up.

Sensing loss test

Open connection W on the AVR terminal and start the AVR at 400V. The sensing loss LED will light up and the bulb will be ON for 5 sec and then switch OFF.

Stability test

The bulb dimming rate during the voltage control test depends upon the AVR stability setting. At minimum stability, the bulb will switch ON and OFF around the voltage setpoint. A higher stability setting will decrease the speed of bulb dimming and brightening.

Voltage range

The AVR voltage range can be checked by performing a voltage control test for V potentiometer min and V potentiometer max. This test gives the approximate voltage range values.

UFRO test

The UFRO factory setpoint is around 47.5Hz. Set the variac output to 410VAC. Turn the UFRO potentiometer clockwise until the UFRO LED turns ON. One more clockwise turn of the UFRO potentiometer will gradually switch OFF the bulb.

R180

AVR

9 - DIMENSIONS

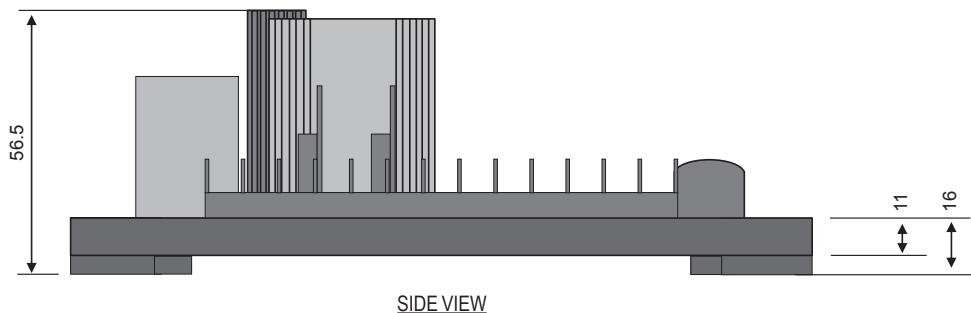
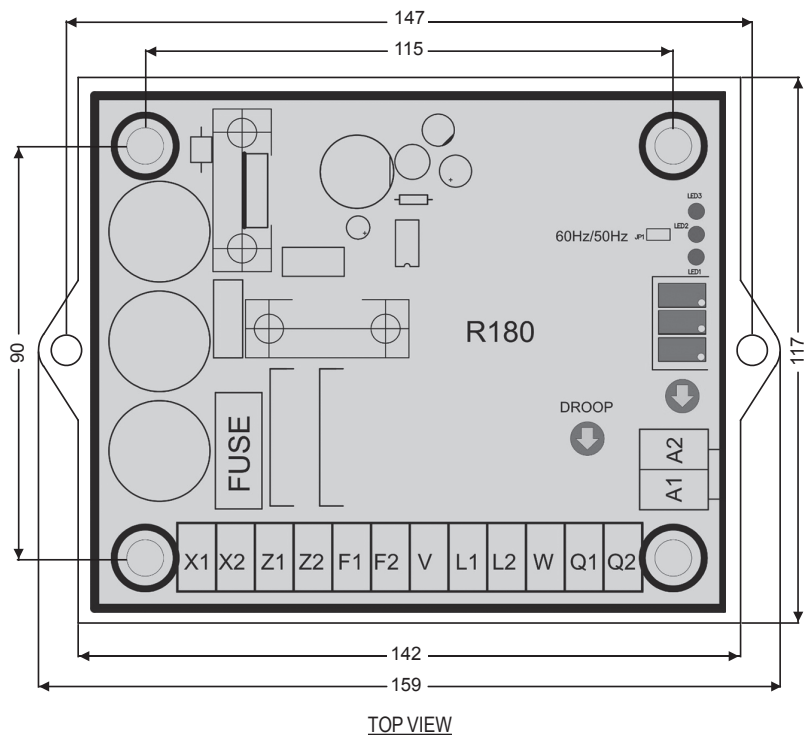

R180 AVR

10 - SPARE PARTS

10.1 - Designation

Description	Type	Code
AVR	R180	5089747

10.2 - Technical support service

Our technical support service will be pleased to provide any additional information you may require.

For all spare parts orders or technical support requests, send your request to service.epg@leroy-somer.com or your nearest contact, whom you will find at www.lrsm.co/support indicating the type and the code number of the AVR.

To ensure that our products operate correctly and safely, we recommend the use of original manufacturer spare parts.

In the event of failure to comply with this advice, the manufacturer cannot be held responsible for any damage.

R180

AVR

Disposal and recycling instructions

We are committed limiting the environmental impact of our activity. We continuously monitor our production processes, material sourcing and products design to improve recyclability and minimise our environmental footprint.

These instructions are for information purposes only. It is the user's responsibility to comply with local legislation regarding product disposal and recycling.

These components are usually marked with information concerning the type of plastic. All materials listed above need special treatment to separate waste from reclaimable materials and should be entrusted to specialist recycling companies.

Waste & hazardous materials

The following components and materials require special treatment and must be separated from the alternator before the recycling process:

- electronic materials found in the terminal box, including the automatic voltage regulator (198), current transformers (176), interference suppression module and other semi-conductors.
- diode bridge (343) and surge suppressor (347), found on the alternator rotor.
- major plastic components, such as the terminal box structure on some products.

R180
AVR

Service & Support

Our worldwide service network of over 80 facilities is at your service.

This local presence is our guarantee for fast and efficient repair, support and maintenance services.

Trust your alternator maintenance and support to electric power generation experts. Our field personnel are 100% qualified and fully trained to operate in all environments and on all machine types.

We have a deep understanding of alternator operation, providing the best value service to optimise your cost of ownership.

Where we can help:

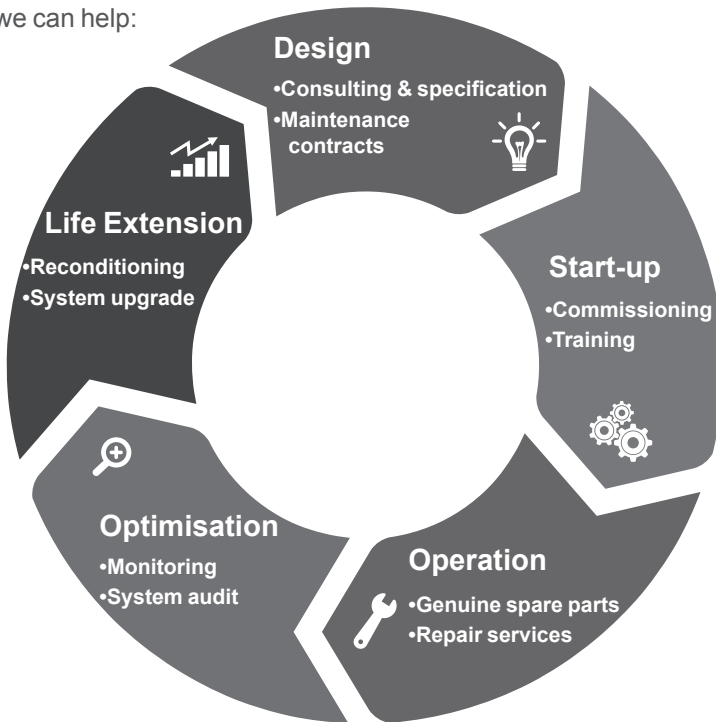

Contact us:

Americas: +1 (507) 625 4011

Europe & Rest of the world: +33 238 609 908

Asia Pacific: +65 6250 8488

China: +86 591 88373036

India: +91 806 726 4867

Middle East: +971 4 5687431

 service.epg@leroy-somer.com



Scan the code or go to:

www.lrsr.co/support

LEROY-SOMERTM

www.leroy-somer.com/epg

[Linkedin.com/company/leroy-somer](https://www.linkedin.com/company/leroy-somer)

[Twitter.com/Leroy_Somer_en](https://twitter.com/Leroy_Somer_en)

[Facebook.com/LeroySomer.Nidec.en](https://www.facebook.com/LeroySomer.Nidec.en)

[YouTube.com/LeroySomerOfficiel](https://www.youtube.com/LeroySomerOfficiel)



Nidec
All for dreams